



# Space-ette® Series Flush to Wall Refrigerated Air Cooled Floor Mounted

## Models FD7003\*, FD7005\*, FD70010\* & FD700D\*

### SPECIFICATIONS

#### PRODUCT SPECIFICATION

Self-contained, electric floor model water cooler. Capacity of 50°F drinking water, based upon 80°F inlet water and 90°F ambient. Model FD700D\* is non-refrigerated and shall deliver non-chilled drinking water. Cabinet design allows for flush to wall installation. Removable front panel and cabinet sides. Non-Pressurized tank system is standard.

Non-Pressurized tank system is standard. Non-pressurized water tank is located after bubbler valve, so that tank is subject to line pressure only when valve button is pressed.

Unit shall be lead-free design which is certified to NSF/ANSI 61 and 372 and meets Federal and State low-lead requirements. Unit shall be certified to UL399 and CAN/CSA 22.2 No. 120.

#### STANDARD FEATURES

- Extra deep basin minimizes splashing; with integral vandal-resistant strainer
- Exclusive Flexi-Guard® Safety bubbler
- Cooler Panel Finish: Impact-resistant vinyl coating or Stainless Steel
- Rated for Indoor use

#### COOLING SYSTEM

- Compressor: Hermetically-sealed, reciprocating type, single phase. Sealed-in lifetime lubrication.
- Condenser: Fan cooled, copper tube with aluminum fins. Fan motor is permanently lubricated.
- Cooling Unit: Combination tube-tank type. Tube portion is continuous coil of copper tubing. Fully insulated with EPS foam which meets Underwriters Laboratories Inc. Requirements for self extinguishing material.
- Refrigerant Control: Refrigerant R134a is controlled by accurately calibrated capillary tube.
- Temperature Control: Easily accessible enclosed adjustable thermostat is factory preset. Requires no adjustment other than for altitude requirements.

RATED FOR INDOOR USE ONLY



#### CONSTRUCTION

- Stainless Steel basin with integral vandal-resistant strainer
- Galvanized structural steel cooler chassis provides structural integrity
- Cooler cabinet available as Light Gray Granite or Sandalwood Vinyl Clad Steel or Stainless Steel (additional cost) construction
- Exclusive Flexi-Guard® Safety bubbler utilizes an infused anti-microbial pliable polyester elastomer to prevent accidental mouth injuries. Flexes on impact
- † Option for additional Glass Filler (ordered separately)

**Warranty:** 5 year limited warranty on the unit's refrigeration system. Electrical components and water system are warranted for 12 months from date of installation or 18 months from factory shipment, whichever date falls first.

CAPACITIES CHART						† Glass Filler (option) (F) available at extra cost (order separately) Requires Factory prep to receive glass filler		
Model	Voltage / Hertz	Chilling** Capacity	F.L. Amps	Rated Watts	Approx. Ship Wt.			
† FD7003*1Z	115V / 60Hz	3.0 GPH	3.5	230	54 lbs.	YES	•	•
† FD7003*2YJO	220V / 50Hz	2.5 GPH	2.0	230	54 lbs.	YES	++	•
† FD7003*3YJO	220V / 60Hz	3.0 GPH	2.0	230	54 lbs.	YES	++	•
† FD7005*1Z	115V / 60HZ	5.0 GPH	3.5	230	54 lbs.	YES	•	•
† FD7005*2YJO	220V / 50Hz	4.2 GPH	2.0	230	54 lbs.	YES	++	•
FD7005*3YJO	220V / 60Hz	5.5 GPH	2.0	230	54 lbs.	YES	++	•
† FD70010*1Z	115V / 60Hz	9.8 GPH	6.8	535	65 lbs.	YES	•	•
† FD70010*2YJO	220V / 50Hz	8.2 SPH	2.5	535	65 lbs.	YES	++	•
FD70010*3YJO	220V / 60Hz	10.8 GPH	3.0	535	65 lbs.	NO	++	•
FD700D*	–	–	–	–	29 lbs.	NO	•	•

\*Color code of (L) Light Gray Granite, (T) Sandalwood, or (S) Stainless Steel cooler panels.

\*\*Based on 80°F inlet water & 90°F ambient air temp for 50°F chilled drinking water.

† Glass Filler available at extra cost. (Use Code (F)). Requires factory preparation to receive glass filler. (Glass Filler ordered separately.)

++Complies; not third party certified.

*This specification describes an Elkay product with design, quality and functional benefits to the user. When making a comparison of other producer's offerings, be certain these features are not overlooked.*

# Space-ette® Series Flush to Wall Refrigerated Air Cooled Floor Mounted

## Models FD7003, FD7005, FD70010 & FD700D ROUGH-IN DIMENSIONS

Open space rough-in design permits new installation or replacement of existing fountains and coolers with this Elkay cooler when rough-in is within the outline shown.

**RATED FOR INDOOR USE ONLY**

### IMPORTANT! INSTALLER PLEASE NOTE:

This water cooler has been designed and built to provide water to the user which has not been altered by materials in the cooler waterways.

The grounding of electrical equipment such as telephone, computers, etc. to water lines is a common procedure. This grounding may be in the building or occur away from the building. This grounding can cause electrical feedback into a water cooler creating an electrolysis which creates a metallic taste or causes an increase in the metal content of the water. This condition is avoidable by installing the cooler using the proper materials as shown below.

### NOTICE

This water cooler must be connected to the water supply using a dielectric coupling. The cooler is furnished with a non-metallic strainer which meets this requirement. The drain trap, which is provided by the installer, should also be plastic to completely isolate the cooler from the building plumbing system.

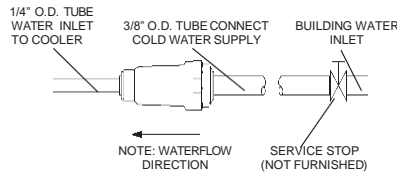

### OPERATION OF QUICK CONNECT FITTINGS

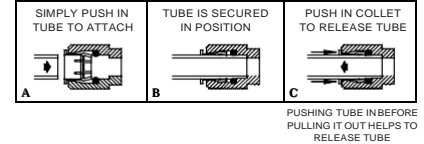

FRONT VIEW

SIDE VIEW

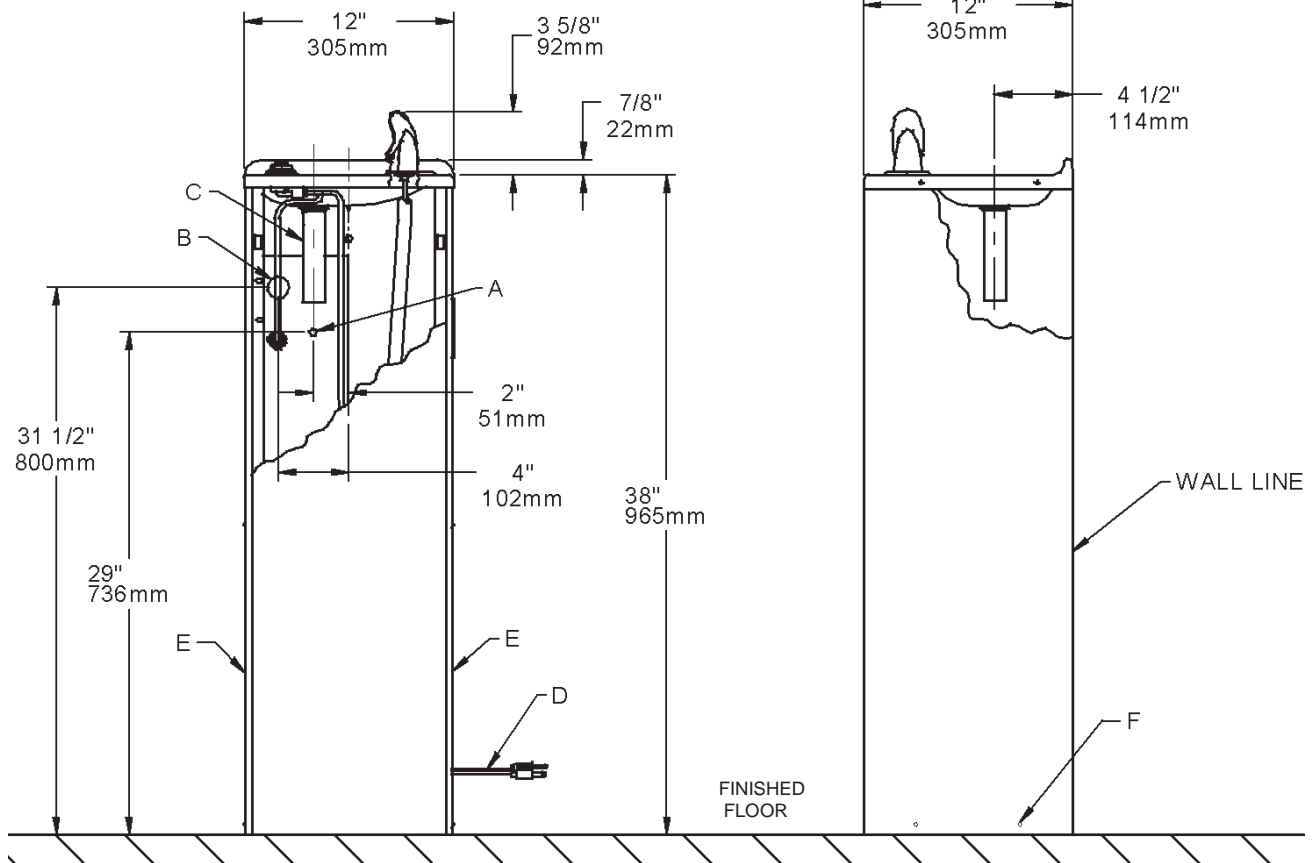

### LEGEND

- A = RECOMMENDED WATER SUPPLY LOCATION. SHUT OFF VALVE (NOT FURNISHED) TO ACCEPT 3/8 O.D. UNPLATED COPPER TUBE.
- B = RECOMMENDED LOCATION FOR WASTE OUTLET 1-1/4" O.D. DRAIN
- C = 1-1/4" TRAP NOT FURNISHED
- D = POWER CORD 4 FEET (1219mm) LONG
- E = INSURE PROPER VENTILATION BY MAINTAINING 4" (102mm) (MIN.) CLEARANCE FROM CABINET LOUVERS TO WALL.
- F = TO LEVEL UNIT, LOOSEN SCREWS TO ADJUST BASE FOR CONTACT WITH FLOOR. TIGHTEN SCREWS AFTER UNIT HAS BEEN LEVELED.

Job Name: \_\_\_\_\_

Model: \_\_\_\_\_ Qty. \_\_\_\_\_

Contact: \_\_\_\_\_

Approval Signature: \_\_\_\_\_

Notes: \_\_\_\_\_