



- Operating pressure: 0,3 - 10 bar
- Flow rate: single-lever mixer: approx. 11l/min. (3 bar)
- Sensor: approx. 5l/min. (1 - 5 bar)
- Flexible hoses: 35 cm
- Angle valve connection: G 1/2"
- Filters: 0,5 mm mesh size
- Sensor-sensitivity: automatic self-adapting sensor technology
- Sensor range: activation of object recognition (approx. 25 cm) per close sensors (approx. 5 cm)
- Follow-up time: 1 sec. pre-set (adjustable with iqua-click 0 - 10 sec)
- Continuous water flow and hygienic rinse time: 2 min. pre-set (adjustable with iqua-click 0,5 - 20 min.)
- Temporary-off: 2 min. (fixed)

Engineering standards: DIN EN 200;CE

PRODUCT SPECIFICATIONS

Hybrid kitchen faucet H10, single lever mixer with IR-sensor, mains operation exposed, chrome

Dimension

375 (H) x 215 (W) mm



TECHNICAL SPECIFICATIONS

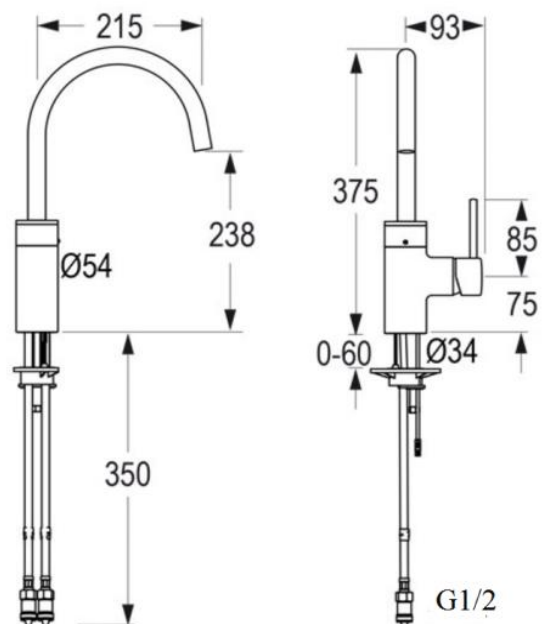

Unit in millimetres.