



- modular single-piece design, without separate installation box, sturdy metal housing, polished
- infrared sensors with automatic setting feature, microprocessor-electronic
- integrated waterproof battery box or cable connection to power supply

WATER EFFICIENCY



PRODUCT SPECIFICATIONS

100.902.11CO

CONTI + Flamingo sensor cold water faucet, battery operated (FL20)

100.913.11CO

CONTI + Flamingo sensor cold water faucet, mains operated (FL20)

Dimension : Height 166mm

TECHNICAL SPECIFICATIONS

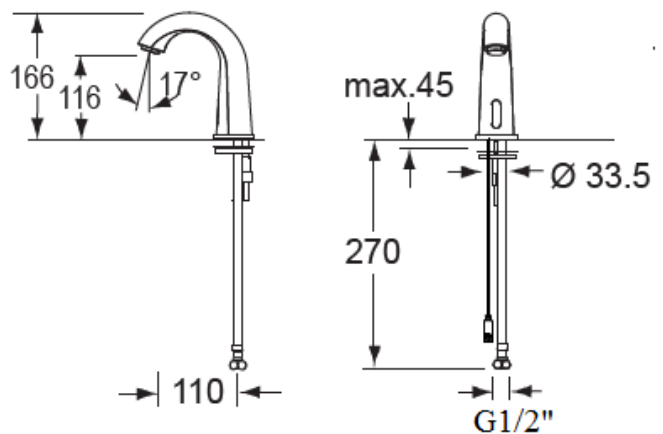

Unit in millimetres.